



**ADVANCED ADAPTIVE™
PIR/MICROWAVE
TECHNOLOGY
SENSOR**

INSTALLATION INSTRUCTIONS

C-200AP

30' RANGE

C-200APC

30' RANGE

U.S. PATENT NO. 5,331,308

WI865A 8/97

TABLE OF CONTENTS

GENERAL DESCRIPTION	3	MOUNTING THE SENSOR	7
SPECIFICATIONS	3	CHANGING THE LENS	8
FEATURES	3	WIRING	8
ORDERING INFORMATION	4	ADJUSTING THE COVERAGE AREA	9
BASIC OPERATION	4	TESTING THE COVERAGE AREA	11
PIR ZONE DIMENSIONS	5	COMPLETING THE INSTALLATION	13
DETECTION PATTERNS	5	OPTIONAL LENSES	14
STANDARD LENS	6	ADVANCED FEATURES	15
INSTALLATION	7	WIRING DIAGRAMS	16
CHOOSING A SUITABLE LOCATION	7		

© NAPCO 1997. All Rights Reserved

Napco Security Systems, Inc., 333 Bayview Avenue, Amityville, New York 11701
Sales, Repairs & Technical Service (Toll Free): (800) 645-9445
Direct Line to Technical Service (Toll Free): (800) 645-9440

GENERAL DESCRIPTION

DESCRIPTION

The C-200AP and C-200APC are dual-technology sensors intended for use in residential or commercial applications where small animals may be present. They feature conventional wide-angle coverage patterns that are insensitive to dogs, cats, etc. weighing up to about 40 pounds. (For larger pets, a conventional Pet-Alley Lens is provided.) The C-200AP uses a Form-A alarm relay; the C-200APC uses a Form-C relay.

SPECIFICATIONS (Note: Not all models are equipped with all features.)

General Coverage with standard lens, measured indoors at 20° C (68° F), typical: 30'x35'

Operating Temperature: -10° to +50° C (14° to 122° F)

Mounting: Wall or corner, 7' to 8' max.

Output Relay: Form A (C-200AP): Normally-Closed; Form C (C-200APC): Normally Closed or Normally Open

Relay Time: Approximately 4 seconds

Contact Ratings: 100mA, 24Vdc with internal 10Ω current-limiting resistor

Trouble: Open collector current sinking with 39Ω current-limiting resistor, 20mA max.

Status Input*: (Form-A Version only) Panel disarmed, >5V; armed, <1.5V.

Self-Test Interval: 11–16 hours.

Power-Supply Requirements

Note: This unit is intended for operation from a power source that provides battery backup in the event of a power failure. For UL installations, the backup battery must be fully recharged within 24 hours and provide 4 hours of standby operation.

Filtered Dc: 12Vdc

Current Drain at 12Vdc: Idle, 37mA; Alarm, 38mA

Microwave Frequency: 10.525GHz ±25MHz

Physical

Dimensions: 4.5" x 2.5" x 2.3" (HxWxD) (11.4cm x 6.4cm x 5.8cm)

Shipping Weight: 7oz (200gm)

FEATURES

- Microprocessor signal processing.
- Power-up system diagnostic tests virtually all electronics.
- Microwave and PIR self test.
- Watchdog microprocessor supervision.

*For UL installations, Status Input is to be connected only to a UL-listed control panel with a UL-tested Status line.

- Microwave circuit supervision.
- 4-Pulse Mode for hostile environments.
- Quick-Response Mode while disarmed.
- Form-A or Form-C relay version available.
- Trouble Output.
- Automatic PIR operation on microwave failure.
- Dual-element PIR sensor
- High-efficiency, dirt-resistant grooves-in lens.
- Extensive RFI and EMI filtering ensure optimum immunity to false alarms.
- Large lens area assures high PIR sensitivity.
- Horizontal as well as vertical aiming capabilities.
- Selectable Microwave/PIR LED indication visible from virtually any angle, extinguishable after testing.
- Small size; modern, unobtrusive design..
- Silent operation
- Bracket-free corner or wall mountable.
- Universal Swivel Bracket Kit available.

ORDERING INFORMATION

C-200AP Dual Technology Microwave/PIR Detector (Form-A Relay)
 C-200APC Dual Technology Microwave/PIR Detector (Form-C Relay)
 SVLBKT Swivel Bracket Kit
 LENS817 Pet-Alley Lens

BASIC OPERATION

These units comprise a passive-infrared sensor and microwave sensor housed in a single package. The unit will go into alarm when both PIR and microwave sensors detect intrusion at the same time. The design is such that small animals within the coverage area will not be detected.

The PIR section operates by detecting a rapid change in temperature when an intruder crosses a protected area. When a beam experiences a change in heat (projected back through the lens), a pulse is generated by the sensor element. The microwave transmitter sends out short bursts of rf energy, and the receiver detects changes in the returned signal caused by motion within its coverage area.

The microwave section is unaffected by visible light, air drafts, or temperature changes (as from space heaters or air conditioners, for example), but is sensitive to motion. Strong vibrations can be troublesome. Microwave signals may pass through non-metallic walls and windows. Infrared is virtually unaffected by vibration, and will not penetrate walls or windows.

Thus the two complementary technologies provide an inherent immunity to false alarms. Dual technology is ideal for use in hostile environments. Since both must trip simultaneously to cause an alarm, installation is easier and requires less discipline.

PIR ZONE DIMENSIONS

Regardless of the lens pattern selected, or the number of PIR beams produced by the lens, the relative proportions of beam width, beam height, beam separation, and zone width always remain the same and are illustrated in Fig. 1. Note that beam and zone dimensions at any distance may be calculated by the following formulas.

Beam Width "w" (in.) = Distance "d" (ft.) x 0.4

Beam Separation "s" (in.) = Distance "d" (ft.) x 0.4

Beam Height "h" = 2 x Beam Width "w"

Zone Width "z" = 3 x Beam Width "w"

Examples: At 10', a zone is 8" high x 12" wide.; at 30', it is 2' high x 3' wide.

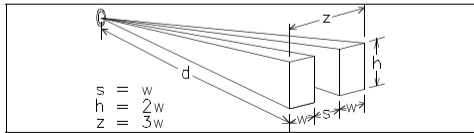

Fig. 1. Relative Zone Proportions.

DETECTION PATTERNS

Figure 2 illustrates maximum PIR and microwave detection patterns superimposed on each other. PIR detection patterns are adjustable, within limits, both vertically and horizontally (see **ADJUSTING THE COVERAGE AREA** for detailed adjustment procedures).

The microwave detection patterns shown are for free space. In practice, when confined by walls and ceilings, reflected waves tend to flood the area, providing volumetric coverage. Furthermore, when used in long, narrow corridors, the effective range may be extended by as much as a factor of 2 due to the guiding effect that the corridor has on microwave energy. Microwave detection range is adjustable. Reducing range, however, will reduce all other dimensions proportionately.

Insensitive Areas

The insensitive area is that area directly beneath the unit within which an intruder is undetectable. It is shown as a shaded area in the side-view detection pattern that follows, and assumes that an intruder will be at least 5' tall and that the protected area is not accessible by crawling or crouching. The size of the insensitive area will increase as the mounting height increases (see Fig. 2b). Nevertheless, it may be necessary to increase the mounting height in order to avoid an object that could obstruct the coverage pattern.

STANDARD LENS

This model uses a standard lens that yields the 18-zone, 40-beam pattern illustrated in Fig. 2. The coverage pattern is adjustable, within limits, both vertically and horizontally (see **ADJUSTMENTS: Aiming the Beams** for detailed adjustment procedures). Stacked optical centers provide tall, dense beam pairs, making beam aiming easier and less critical. Examples shown herein are typical and will not apply to all cases. Always test the coverage pattern after the unit is installed (see **TESTING THE COVERAGE AREA**).

The supplied lens will perform best in typical applications, thus it is factory installed. Following are its specifications.

Number of Zones: 18 (3 layers: 9/5/4 zones)

Number of Beams: 40 (3 layers: 18/10/12)

Maximum Coverage: 30' long x 35' wide

Field of View: 85°

Mounting Height: 7 to 8'

Note: (1) If heavily soiled, clean lens using lukewarm water and a mild detergent. Dry with soft lint-free cloth or allow to air dry. (2) If lens is not suitable, select another (see **ORDERING INFORMATION**).

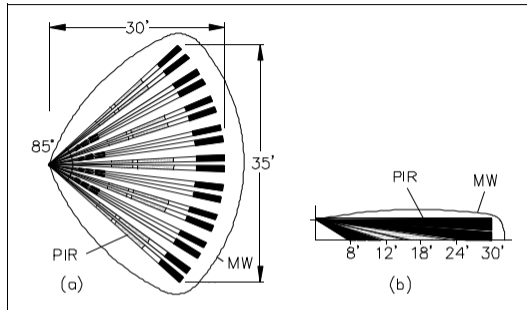

Fig. 2. Standard lens patterns showing maximum recommended coverage: (a) top view; (b) side view for 6' mounting height.

INSTALLATION

IMPORTANT! For optimum results in pet applications,

- Mount the unit at 7–8', adjust the microwave gain control to the minimum setting required to detect a intruder.
- Choose a location where the pet cannot get close to the unit.
- Adjust microwave for minimum range that gives desired detection.
- If protecting an area with a pet over 2'6" or 50 lbs., mount unit at a height of approx. 5 to 6 feet and install lens (P/N: LENS817).

CHOOSING A SUITABLE LOCATION

The unit may be either wall mounted or corner mounted. Select a rigid surface that is relatively free of vibration.

Positioned the sensor with respect to access doors or windows so that an intruder will pass **across** its field of view, not directly toward or away from it. Avoid areas containing devices that may pose a chronic problem to either sensor. For the dual-technology feature to be truly effective in rendering the unit free from false alarms, neither sensor should detect intrusion under normal conditions. **Note:** The unit is shipped from the factory with Jumper J1 in the Alarm position.

In selecting mounting height, aiming, and range, also consider the following:

- (1) the size and shape of the area to be protected. In a large or irregularly-shaped area, the use of two or more units may be advisable for volumetric coverage;
- (2) the PIR lens installed (see **ORDERING INFORMATION** for available optional lenses);
- (3) objects that may block detection;
- (4) animals in the protected area; and
- (5) an intruder's likely path, usually determined by the location of a door or window.

MOUNTING THE SENSOR

Open the case by inserting a small screwdriver in the slot at the bottom and pushing up slightly. Remove the front cover.

An array of "push-thru" holes is provided in the rear case to simplify wall or corner mounting. (If corner mounting, do not use the hole at the lower-left corner, near the terminal strip.) A round push-thru hole permits cable entry at the bottom (see Fig. 4). Cutaway notches in the rear case will accommodate surface-mounted cables if the outer jacket is removed. **Note:** Any knockout that has been removed but not used should be sealed with the caulking material supplied to eliminate drafts and prevent entry by insects.

WARNING: This unit will not detect pets under 2'6" in height or under 40 lbs. in weight.

CHANGING THE LENS

The lens is “sandwiched” between the front case and a Lens Support Insert, which also serves to hold the LED jewel in place. To install one of the accessory lenses, proceed as follows.

1. Push up on the lower edge of the Lens Support (see Fig. 3) until it is clear of its retainers, then pull out the Lens Support from the bottom. Be careful not to dislodge the LED jewel. **Note:** If the jewel pops out, re-insert it with the small index key positioned at the top.

2. Slide out the lens and install the replacement correctly oriented.

3. Replace the Lens Support: Slip the Lens Support under the top lens guides with its two tabs straddling the LED jewel, then push in at the bottom until the Lens Support snaps into place.

WIRING

Remove the wire entry hole (see **MOUNTING THE SENSOR**) to gain access to the terminal strip. (Be sure to caulk around the wires where they exit the case; see previous Note.) Route wires to the terminal strip as shown in Fig.

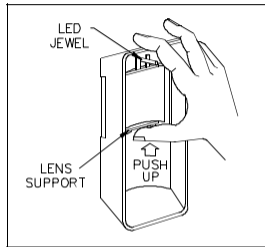

Fig. 3. Removing the

4 and connect as follows:

Power (Terminals 1 [+] & 2 [-]). Apply 12Vdc to Terminals 1 [+] and 2 [-]. The power source may be regulated or unregulated. Power should be supplied from a control panel or other power source equipped with a rechargeable battery backup to maintain operation in the event of a power failure. Refer to **SPECIFICATIONS** for power-supply requirements.

Alarm Relay (Form A) Contacts (Terminals 3 & 4). These contacts are rated at 100mA, 24Vdc and are normally closed. When the sensor is operating, either detection of an intruder or loss of power will cause the relay contacts to open. (This mode of operation is required in UL installations.)

Alarm Relay (Form C) Contacts (Terminals 3, 4 & 5). These contacts are rated at 100mA, 24Vdc. Terminal 4 is common. Terminal 3 is normally closed; Terminal 5 is normally open. When the sensor is operating, either detection of an intruder or loss of power will cause the relay to trip. (In UL installations, normally-closed terminals (3 and 4) must be used.)

Status (Form-A Version only) and Trouble (Where equipped)

Wiring to Terminals 5 (Status) and 6 (Trouble) are only required if using the special features of this unit. Refer to **ADVANCED FEATURES** and the Wiring Diagrams at the back.

Status Input (Form-A Version only, Terminal 5). Connect to the Status terminal (Arm Lug) of the control panel. A low at Terminal 5 tells the sensor

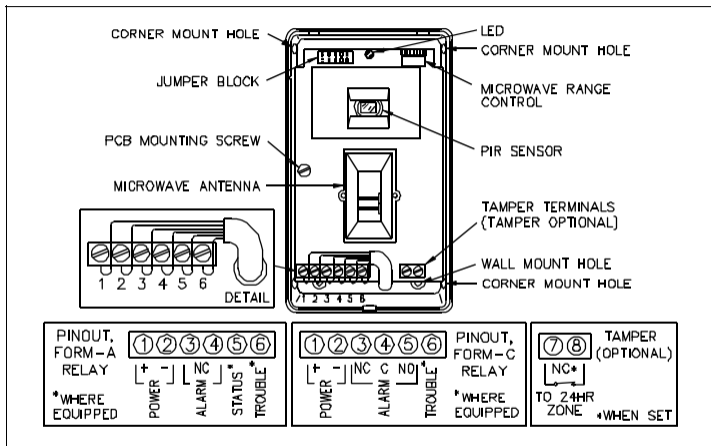

that the panel is armed.

Trouble (Terminal 6). This is an open-collector output that produces an active low to signal a trouble condition.

ADJUSTING THE COVERAGE AREA

Self Test

The self-test diagnostic simulates motion and tests the PIR sensor, amplifier and related PIR circuitry, the microwave transmitter, receiver, and associated microwave circuitry. This test is initiated each time the unit is powered up and randomly at 11- to 16-hour intervals after the last alarm to assure that the unit is always in operating order. At power-up, the LED will come on and both the alarm and trouble outputs will be held "safe". If the unit is operating properly, the LED will extinguish after about 1 minute. However, if it fails the self test, the LED will flash rapidly, indicating a need for service. After the LED goes out, indicating a successful self-test, proceed as follows.

Lateral Beam Adjustment

PIR beams may be shifted up to 6° in either direction ($\pm 1/2$ zone for the Standard Wide-Angle lens). The left edge of the top lens guide acts as the index for lens alignment. Figure 5 illustrates the relative positions of the index and lens alignment notches. To align a lens, proceed as follows. (**Caution:** To prevent soiling, handle the lens only with clean fingers.)

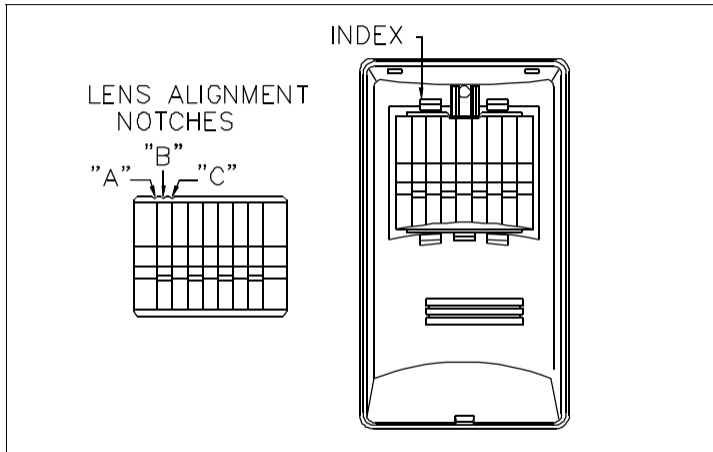

Fig. 5. Inside front cover showing lens alignment notches.

1. Check that lens is installed smooth side out, grooved side in.
2. To aim beams straight out, set Notch "B" to left edge of top lens guide.
3. To aim beams 6° to the right, set Notch "A" to left edge of top lens guide.
4. To aim beams 6° to the left, set Notch "C" left edge of top lens guide.

Jumper Block

The Jumper Block (see Fig. 6) is used to select operating modes, as follows:

LED. LED Disable. Install to disable LED Alarm indication only.

PIR. PIR Walk-Test Mode. LED indicates PIR trips only.

ALARM. Alarm. LED indicates simultaneous PIR and Microwave trips.

MW. Microwave Walk-Test Mode. LED indicates microwave trips only.

Important! The alarm relay will operate only with the LED jumper installed or the ALARM jumper installed. Therefore, after testing, be sure to replace the jumper in the ALARM position for normal LED operation, or in the LED position, which prevents the LED from lighting on an alarm condition.

Four-Pulse Mode. This is the least-sensitive mode, recommended for hostile environments or areas with pets larger than about 40 pounds, where

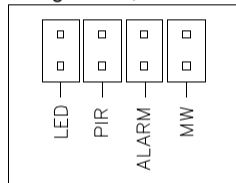

Fig. 6. Jumper block

an intruder must cross several beam pairs to trip an alarm. To lock the unit into the 4-Pulse Mode while maintaining adaptive microwave operation, install both the PIR jumper and the MW jumper.

Microwave Range Adjustment

Important! The microwave RANGE ADJUST control should be set at the minimum required to achieve the desired coverage. It is set so that the Walk-Test LED lights when motion is detected at the maximum desired range, but does not light (motion is not detected) beyond the maximum desired range. All tests must be made with the front cover in place.

1. Remove the front cover and install the MW jumper.
2. Set the RANGE ADJUST control at mid position. Replace the cover and walk-test the unit. (**Note:** Allow at least 5 seconds after trip for microwave to reset.)
3. If the desired range was insufficient, advance the RANGE ADJUST control slightly clockwise. Repeat the test as necessary, increasing the RANGE ADJUST control each time until motion is detected at the desired range, but not beyond. (If the desired range was excessive, reduce the RANGE ADJUST control slightly (counterclockwise) and repeat this step.)

Note: Return the jumper to the ALARM or LED position after adjustment.

TESTING THE COVERAGE AREA

After the unit has been mounted and set up, its coverage should be tested

and, if necessary, altered to accommodate local environmental conditions (within the coverage area). Satisfactory checks may be made using the Walk-Test LED on the front of the unit. It is recommended that the coverage area be tested at least once a year.

Testing the Unit

Complete connections to the terminal strip (see **WIRING**). The unit will require a 1-minute “settling” time to adjust itself to the surrounding temperature. After sufficient time has been allowed, proceed as follows.

Move your hand slowly across the lens to verify sensor operation. With the PIR jumper installed, the LED will light whenever a beam is disturbed. With the MW jumper installed, the LED will light as long as motion is detected. When the LED goes out, no motion is detected.

Test the range of the coverage. Install the PIR Walk-Test jumper and replace the front cover. Walk out to the maximum determined coverage distance, then walk across the field of coverage. The LED will remain lit as long as motion is detected. Repeat this test with the microwave MW Walk-Test jumper installed. Repeat once again with the ALARM jumper installed. Confirm that the LED lights at the maximum desired range, **but not beyond**.

Test the width of the coverage. Install the PIR Walk-Test jumper (Fig. 6) and replace the front cover. Walk across the coverage area and confirm LED response. Repeat with the MW Walk-Test jumper installed, and once again

with the ALARM jumper installed.

Test for environmental disturbances.

Note: The following test is applicable to the PIR section only. There are no provisions for testing the microwave section for environmental disturbances.

This test will determine if detection occurs with no human activity in the protection area. Be sure to make this test with all potential disruptive devices (heaters, air conditioners, etc.) in full operation. Note that blowing curtains may be troublesome.

Install the PIR Walk-Test jumper. Leave the protection area. If an alarm condition occurs with no one in the coverage area, temporarily block the entire lens with a sheet of cardboard or other opaque material. If the alarm condition persists with the lens covered, it is not caused by an environmental disturbance, and the system requires attention. (Check for low supply voltage from the control center, or for an intermittent connection.)

Remove the cardboard (or other material) from the front of the lens. If the alarm condition reoccurs, turn off heaters, air conditioners, etc. one by one and note the effects. If the offending device must remain in operation within the coverage area, try to reposition the device and/or alter the aim of the sensor slightly to effect a suitable compromise. Bear in mind, however, that each time the coverage pattern is altered, the foregoing environmental test must be repeated.

Zone Masking

If a workable solution cannot be achieved using the above technique, selective zone masking will be required. This will deactivate a problem zone in order to preserve reliable system operation. Carefully apply a piece of zone-masking foil (supplied) to the grooved inside surface of the lens segment representing the problem zone to block signal from the offending device (refer to Figs. 7 and 8).

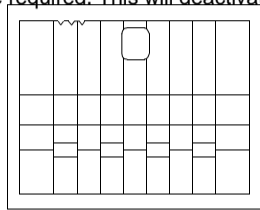

Fig. 7. Zone-masking foil (shaded area) applied to a lens segment to deactivate a problem zone. Also see Fig. 8.

Figure 8 illustrates the zone-masking foil supplied. Remove one or more segments that most closely match the lens segment of the offending zone and affix to the inside surface of the lens. Note that the foil must be accurately positioned so as not to affect adjacent zones. (Zone segments may be located by holding the lens up to the light.) Any oil or grease on the surface of the lens (or on your fingers) will reduce the adhesive quality of the foil. **Important:** After the foil is properly applied, rub it down against the lens (using the tip of a ball-point pen, for example) to improve surface contact.

If necessary, re-aim and retest the sensor after masking one or more zones.

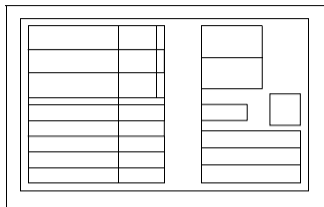

Fig. 8. Zone-masking foil.

COMPLETING THE INSTALLATION

The jumper must be in either the ALARM position or the LED position for the alarm relay to operate. (If the 4-pulse mode is selected, both the PIR and MW

jumpers must be installed.) With the ALARM jumper (or PIR & MW jumpers) installed, the LED will indicate a condition that would cause an alarm if the system were armed. To extinguish the Walk-Test LED after testing, place the jumper across the LED terminals. In this position, the LED is disabled during normal operation, but is enabled for diagnostic indications.

OPTIONAL LENSES

Pet Alley Lens (LENS817)

A pet alley is an insensitive area above floor level that will reduce the

possibility of pets (dogs, cats, etc.) or pests (mice, rats, etc.) from causing an alarm. **Note:** Mount the unit at a height of 6' for this application.

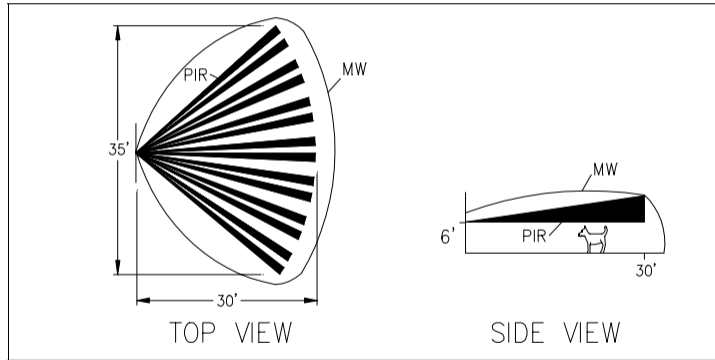

Fig. 9. Pet-Alley Lens coverage pattern.

ADVANCED FEATURES (Where available)

Trouble Output

Terminal 6 is an open collector Trouble output; a trouble condition is indicated by an active low and is maintained. The trouble output may be wired to an unused zone at the panel for local display at the keypad. (In UL installations, connect only to a UL-listed Control Unit Accessory having LED indication.) While troubles can report to a central station, local annunciation may be preferable in order to reduce telephone congestion and operating costs.

Quick Response Mode

If Terminal 5 is connected to the Status Terminal (Arm Lug) of the control panel, the sensor will provide a quicker response time while the panel is disarmed. **Note:** The control panel's Status Terminal must provide a low output when armed.

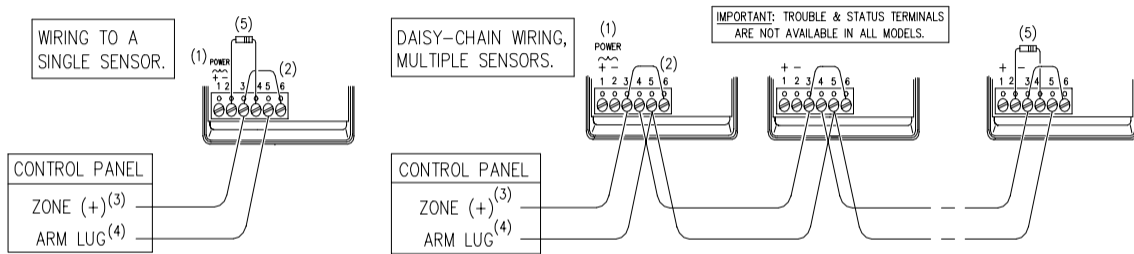

NOTE: (1) WIRE POWER TO ALL SENSORS. (2) CONNECT TERMINAL 3 TO TERMINAL 6 ON ALL UNITS.
 (3) ZONE (-) COMMON WITH AUX. POWER (-); NO ADDITIONAL ZONE WIRING REQUIRED. (4) GOES LOW ON ARMING.
 (5) INSTALL E-O-L RESISTOR BETWEEN TERMINALS 2 & 4 OF LAST SENSOR IN CHAIN. (6) PROGRAM PANEL FOR "TROUBLE ON SHORT".
 (7) IN ACCORDANCE WITH UL REQUIREMENTS, AN ALARM WILL BE SENT ON A TROUBLE CONDITION WHILE ARMED.

Fig. 10. Trouble and Status configuration: alarm sent on trouble condition while armed (four wires; for clarity, power wires not shown).

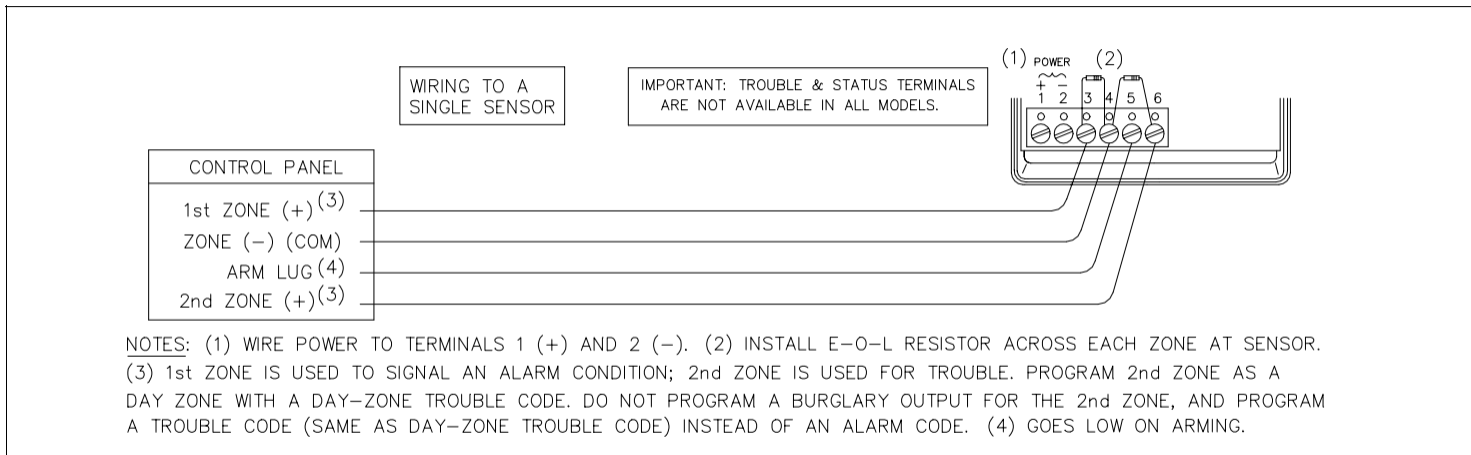

Fig. 10. Trouble and Status configuration: alarm sent on trouble condition while armed (four wires; for clarity, power wires not shown).

NOTES

NAPCO LIMITED WARRANTY

NAPCO SECURITY SYSTEMS, INC. (NAPCO) warrants its products to be free from manufacturing defects in materials and workmanship for thirty-six months following the date of manufacture. NAPCO will, within said period, at its option, repair or replace any product failing to operate correctly without charge to the original purchaser or user.

This warranty shall not apply to any equipment, or any part thereof, which has been repaired by others, improperly installed, improperly used, abused, altered, damaged, subjected to acts of God, or on which any serial numbers have been altered, defaced or removed. Seller will not be responsible for any dismantling or reinstallation charges.

THERE ARE NO WARRANTIES, EXPRESS OR IMPLIED, WHICH EXTEND BEYOND THE DESCRIPTION ON THE FACE HEREOF. THERE IS NO EXPRESS OR IMPLIED WARRANTY OF MERCHANTABILITY OR A WARRANTY OF FITNESS FOR A PARTICULAR PURPOSE. ADDITIONALLY, THIS WARRANTY IS IN LIEU OF ALL OTHER OBLIGATIONS OR LIABILITIES ON THE PART OF NAPCO.

Any action for breach of warranty, including but not limited to any implied warranty of merchantability, must be brought within the six months following the end of the warranty period. IN NO CASE SHALL NAPCO BE LIABLE TO ANYONE FOR ANY CONSEQUENTIAL OR INCIDENTAL DAMAGES FOR

BREACH OF THIS OR ANY OTHER WARRANTY, EXPRESS OR IMPLIED, EVEN IF THE LOSS OR DAMAGE IS CAUSED BY THE SELLER'S OWN NEGLIGENCE OR FAULT.

In case of defect, contact the security professional who installed and maintains your security system. In order to exercise the warranty, the product must be returned by the security professional, shipping costs prepaid and insured to NAPCO. After repair or replacement, NAPCO assumes the cost of returning products under warranty. NAPCO shall have no obligation under this warranty, or otherwise, if the product has been repaired by others, improperly installed, improperly used, abused, altered, damaged, subjected to accident, nuisance, flood, fire or acts of God, or on which any serial numbers have been altered, defaced or removed. NAPCO will not be responsible for any dismantling, reassembly or reinstallation charges.

This warranty contains the entire warranty. It is the sole warranty and any prior agreements or representations, whether oral or written, are either merged herein or are expressly cancelled. NAPCO neither assumes, nor authorizes any other person purporting to act on its behalf to modify, to change, or to assume for it, any other warranty or liability concerning its products.

In no event shall NAPCO be liable for an amount in excess of NAPCO's original selling price of the product, for any loss or damage, whether direct, indirect, incidental, consequential, or otherwise arising out of any failure of the product. Seller's warranty, as hereinabove set forth, shall not be enlarged, diminished or affected by and no obligation or liability shall arise or grow out of Seller's rendering of technical advice or service in connection with Buyer's order of the goods furnished hereunder.

NAPCO RECOMMENDS THAT THE ENTIRE SYSTEM BE COMPLETELY TESTED WEEKLY.

Warning: Despite frequent testing, and due to, but not limited to, any or all of the following; criminal tampering, electrical or communications disruption, it is possible for the system to fail to perform as expected. NAPCO does not represent that the product/system may not be compromised or circumvented; or that the product or system will prevent any personal injury or property loss by burglary, robbery, fire or otherwise; nor that the product or system will in all cases provide adequate warning or protection. A properly installed and maintained alarm may only reduce risk of burglary, robbery, fire or otherwise

but it is not insurance or a guarantee that these events will not occur. CONSEQUENTLY, SELLER SHALL HAVE NO LIABILITY FOR ANY PERSONAL INJURY, PROPERTY DAMAGE, OR OTHER LOSS BASED ON A CLAIM THE PRODUCT FAILED TO GIVE WARNING. Therefore, the installer should in turn advise the consumer to take any and all precautions for his or her safety including, but not limited to, fleeing the premises and calling police or fire department, in order to mitigate the possibilities of harm and/or damage.

NAPCO is not an insurer of either the property or safety of the user's family or employees, and limits its liability for any loss or damage including incidental or consequential damages to NAPCO's original selling price of the product regardless of the cause of such loss or damage.

Some states do not allow limitations on how long an implied warranty lasts or do not allow the exclusion or limitation of incidental or consequential damages, or differentiate in their treatment of limitations of liability for ordinary or gross negligence, so the above limitations or exclusions may not apply to you. This Warranty gives you specific legal rights and you may also have other rights which vary from state to state.